

NOTES:

- ① SEE STANDARD DRAWINGS SD-29.1 AND SD-29.2 FOR PIPE HEADWALL DETAILS.
- ② MATERIAL TO CONFORM TO ASTM DESIGNATION A-36. GALVANIZE ALL EXPOSED FERROUS PARTS AFTER FABRICATION.
- ③ ALL FILLET WELDS TO BE $\frac{3}{16}$ ".
- ④ ALL STEEL SHALL CONFORM TO SECTION 75 OF THE STATE SPECIFICATIONS AND ASTM A36, A575 AND A576.

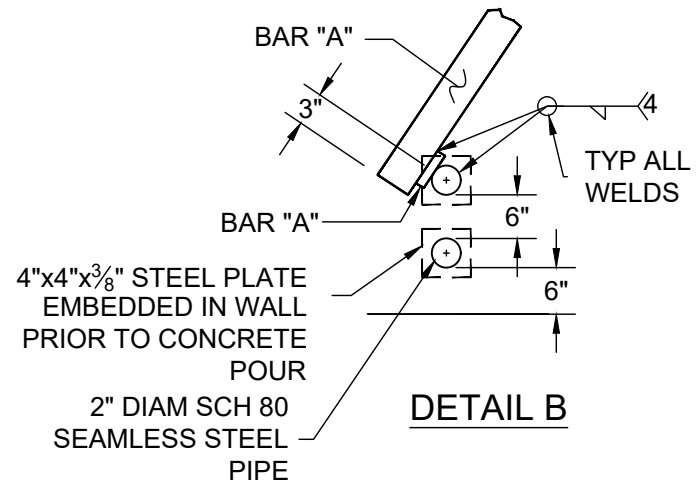
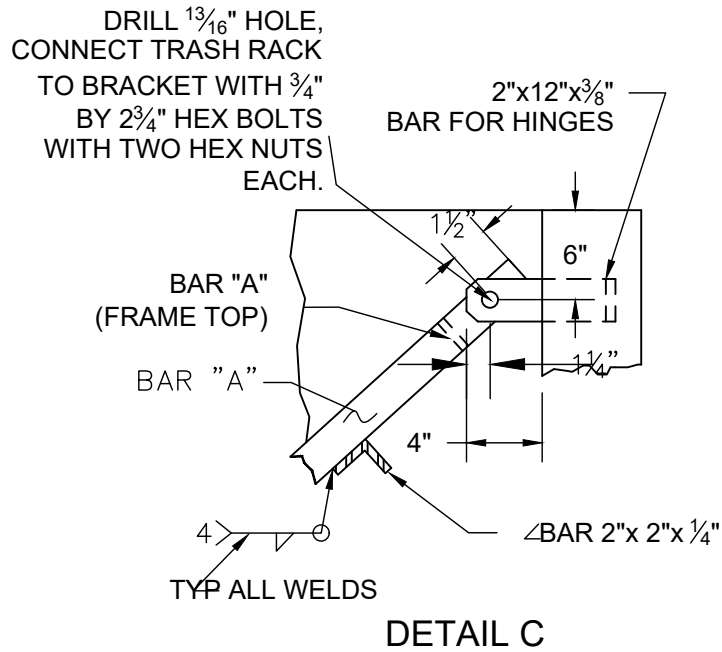

DATE: 09/22/2007		NOT TO SCALE	
REVISION	BY	APPROVED	DATE

CITY OF ELK GROVE - PUBLIC WORKS

**TRASH RACK
DETAILS
(SHEET 4 OF 4)**

APPROVED BY:

Paul M. Muddoch

CITY ENGINEER

10/24/2018

DATE

DRAWING NUMBER

SD - 28.4

